

Soft Slicing Machine

The new dimension in slicing technology

The new WSM 100 D is a technical advanced slicer for soft unfrozen products:

- easy accessible stainless steel base frame
- new roller conveyor to receive sliced products
- double lane high performance production machine
- the fillets are automatically fed through the slicing mechanism and the sliced fillets are placed neatly onto packing trays
- between its two lanes the new WSM 100 D achieves a capacity of up to 120 slices per minute

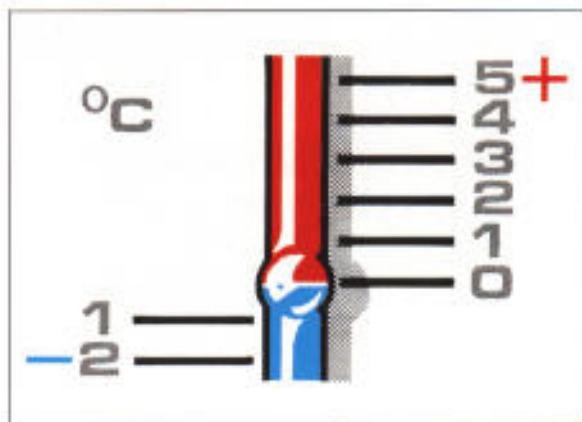

Equipment features:

- even and precise double lane feeding system for fillets up to 195 mm width
- changeable to single lane system (up to 60 slices/min) for fillets of up to 250 mm
- clean slicing with oscillating/reciprocating knives
- adjustable slice thickness during operation
- adjustable cutting angle
- neatly reconstituted sliced fillets are placed onto packing trays
- quick and easy hygienic cleaning
- robust industrial design with the needs of the food processing business in mind
- indispensable to keep ahead in the market

WSM 100 D



For further information
please contact us:

GEBA

SCHNEIDEMASCHINEN · MASCHINENBAU

GEBA-Gerätebau GmbH
Feldmühlenweg 6-10
D-49593 Bersenbrück
Tel. (54 39) 9443-0
Fax (54 39) 9443-40

WSM 100 D

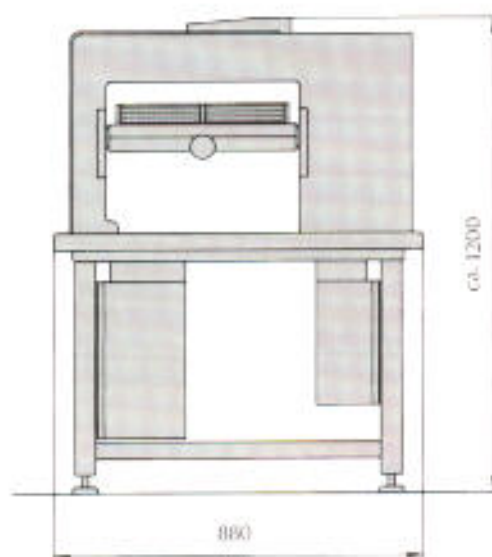
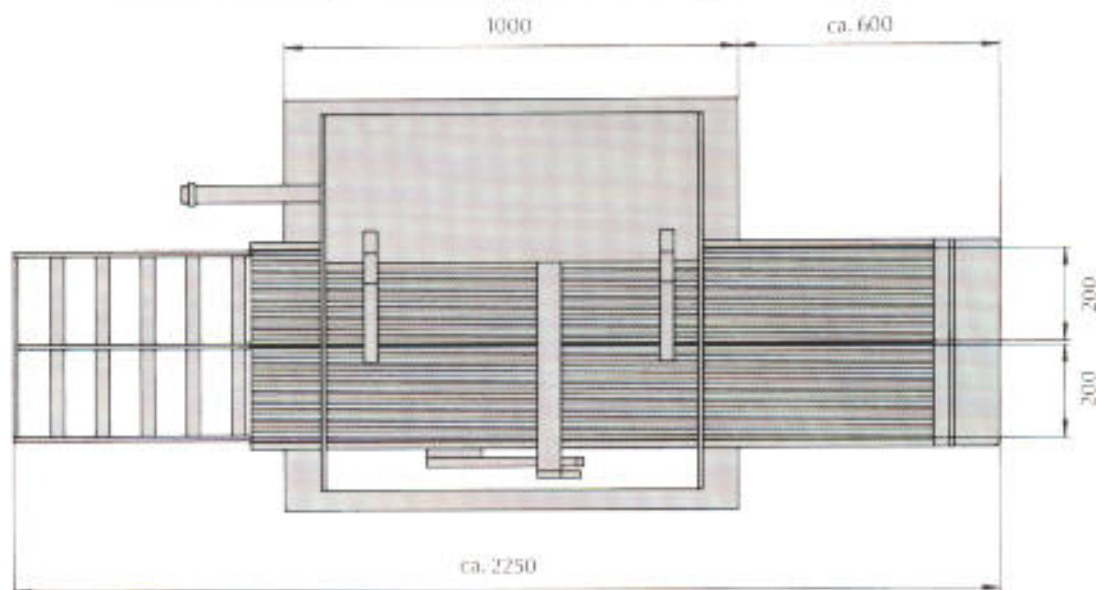
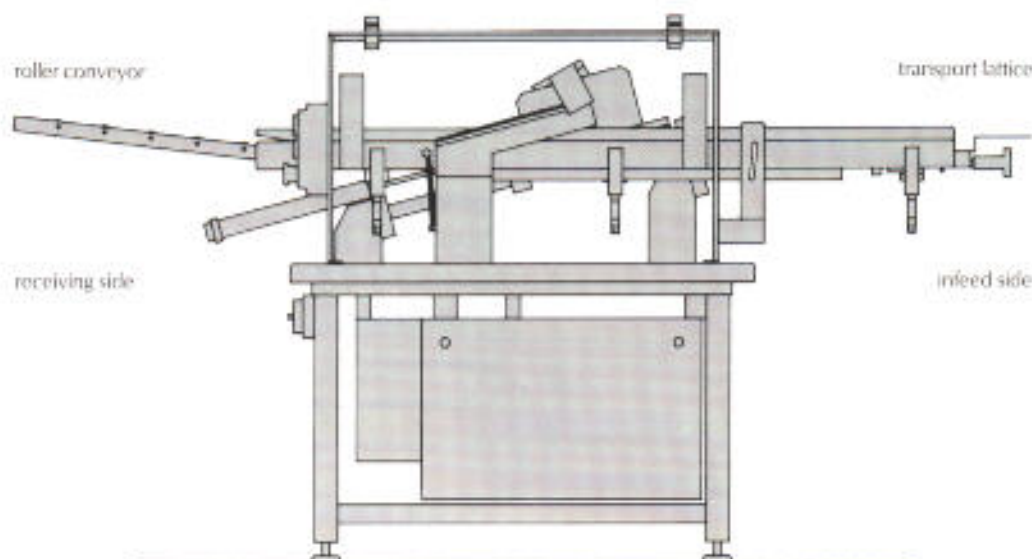

Technical data:

Weight	240 kg		
Oscillating knife	475 mm		
Slice angle	10°-17°	13°-21°	31°-38°
Slice thickness	1,5-4,5 mm	1,5-5,5 mm	1,5-10 mm
Slices per minute	up to 2x 60 = 120		
Compressed air supply	350 l/min, output at 8 to 10 bar		

Electrical data:

Power supply	single phase current, 230-240 V
Power	0,6 kW
Frequency	50 Hz/60 Hz

GEBA

SCHNEIDMASCHINEN - MASCHINENBAU